

# CRIMP FEMALE TERMINAL



## 5312 SERIES. 1.30 (0.051") mm. Diameter.

### General Features

- Accommodates wire range AWG 16 through 20
- Use in housing 1.30 mm. diam. 5300 series
- Round female contact with tin plated locking lance
- Maximum insulation diameter 3.40 mm. (0.134")

### Materials

- Contact: Brass tin plated Brass
- Operating temperature: -25°C to +105°C

### Electrical Features

- Current rating: < 5 A
- Contact resistance: < 10 mΩ

### Mechanical Features

- Wire pull-out force:
  - 7.00 Kgf 16 AWG
  - 6.50 Kgf 18 AWG
  - 6.00 Kgf 20 AWG
- Durability: 25 cycles

### Dimensional Information

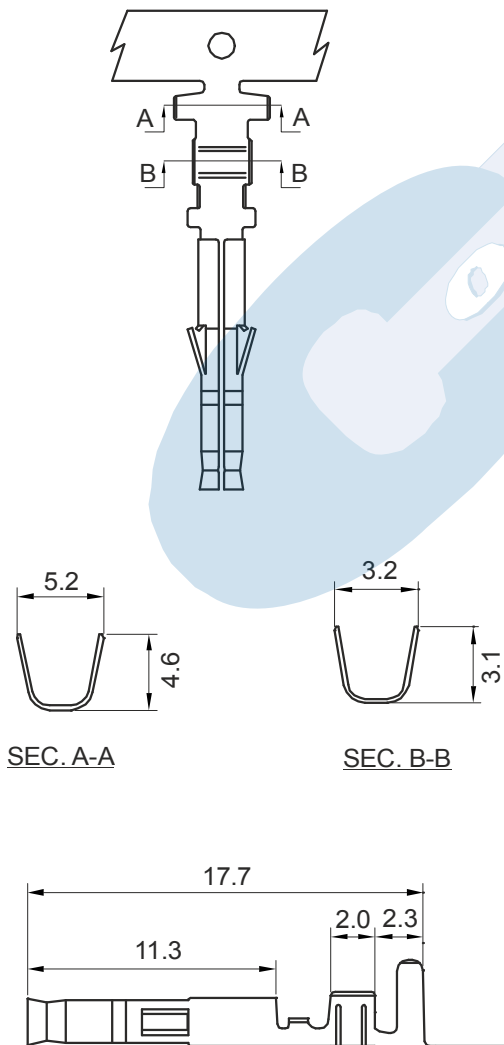

**5312 - T- 00- E**  
1 3

#### 1. Terminal Series

#### 2. (T) Contact Plating

- T = 2. Tin plated

#### . (E) Packing Options

- E = 0. Chain
- E = 1. Loose Piece

